

**FXT Cabinets
FXT600H-A,
FXT600L-A,
FX1350HT-A,
FXT1350L-A**

Service Manual



ISO 14001



ISO 9001



Contents

Environmental Management Policy	1
Disposal Requirements	1
Cabinet description	2
Controller Operation	2 to 4
Alarms and Warnings	3
Information Menu	4
Parameter Setting and Adjustment	4
Parameters	5 to 6
General Arrangements	7 to 8
Technical Data	8
Parts List	9
Wiring Diagram	10 to 21

Environmental Management Policy for Service Manuals and Duets.

Product Support and Installation Contractors

Foster Refrigerator recognises that its activities, products and services can have an adverse impact upon the environment.

The organisation is committed to implementing systems and controls to manage, reduce and eliminate its adverse environmental impacts wherever possible, and has formulated an Environmental Policy outlining our core aims. A copy of the Environmental Policy is available to all contractors and suppliers upon request.

The organisation is committed to working with suppliers and contractors where their activities have the potential to impact upon the environment. To achieve the aims stated in the Environmental Policy we require that all suppliers and contractors operate in compliance with the law and are committed to best practice in environmental management.

Product Support and Installation contractors are required to:

1. Ensure that wherever possible waste is removed from the client's site, where arrangements are in place all waste should be returned to Foster Refrigerator's premises. In certain circumstances waste may be disposed of on the clients site; if permission is given, if the client has arrangements in place for the type of waste.
2. If arranging for the disposal of your waste, handle, store and dispose of it in such a way as to prevent its escape into the environment, harm to human health, and to ensure the compliance with the environmental law. Guidance is available from the Environment Agency on how to comply with the waste management 'duty of care'.
3. The following waste must be stored of separately from other wastes, as they are hazardous to the environment: refrigerants, polyurethane foam, oils.
4. When arranging for disposal of waste, ensure a waste transfer note or consignment note is completed as appropriate. Ensure that all waste is correctly described on the waste note and include the appropriate six-digit code from the European Waste Catalogue. Your waste contractor or Foster can provide further information if necessary.
5. Ensure that all waste is removed by a registered waste carrier, a carrier in possession of a waste management licence, or a carrier holding an appropriate exemption. Ensure the person receiving the waste at its ultimate destination is in receipt of a waste management licence or valid exemption.
6. Handle and store refrigerants in such a way as to prevent their emission to atmosphere, and ensure they are disposed of safely and in accordance with environmental law.
7. Make arrangements to ensure all staff who handle refrigerants do so at a level of competence consistent with the City Guilds 2078 Handling Refrigerants qualification or equivalent qualification.
8. Ensure all liquid substances are securely stored to prevent leaks and spill, and are **not** disposed of to storm drains, foul drain, surface water to soil.

DISPOSAL REQUIREMENTS

If not disposed of properly all refrigerators have components that can be harmful to the environment. All old refrigerators must be disposed of by appropriately registered and licensed waste contractors, and in accordance with national laws and regulations.

CABINET DESCRIPTION

The cabinets are manufactured as a one piece foamed shell.

The condensing unit is located on the top of the cabinet.

The cabinets conform to ISO Climate Class 5.

Temperature is controlled by a LAE microprocessor control with digital temperature display.

The refrigeration system is integral with an air-cooled condensing unit with the refrigerant distribution into the evaporator controlled by capillary.

The refrigerant used is R134a on high temperature models and R404A on freezers.

Vaporisation is provided by a Hot Gas Defrost Coil fixed within the Vaporiser Tray.

The doors are fitted with Pivot hinges, recessed door handle and magnetic door gasket.

All models are fitted with 80mm castors, swivel to the rear and swivel/lockable to the front.

Controller Operation



LD1 Controller as used on High temperature Models



LD2 Controller as used on Low temperature Models

Operation Guidelines

Initial Start Up.

Start Up & self Test:

The indication is only displayed during the first three seconds following the mains electrical power being applied to the unit. During this period the controller performs a self-check.

Once the self-check has been completed will be displayed.

Press and hold for three seconds. The unit will start and the air temperature will be displayed.

Check set point by pressing the button

To increase on high temperature models set point press + until required temperature is displayed.

To decrease set point press + until required temperature is displayed.

Refrigerator Factory Temperature Set Point +1°C to +4°C

To increase on low temperature models set point press + until required temperature is displayed.

To decrease set point press + until required temperature is displayed.

Freezer Factory Temperature Set Point -19°C to -21°C

Exit from set up occurs after 10 seconds if no button is pressed.

Manual Defrost.

To initiate a manual defrost press and hold when is displayed release.

On completion of the defrost will be displayed until the cabinet temperature is achieved and then it will revert to displaying the normal cabinet temperature.

Set Unit to Standby.

Press  display  shows

This indication is displayed while the unit is not operating but with mains power applied to the unit. This mode may be used for internal cleaning regimes and short periods when the unit is not required. For extended periods of inactivity the mains supply should be isolated.

Alarm and Warnings

High temperature alarm

 Will be displayed.

The alarm will sound but can be silenced by pressing any of the buttons, however it will return after the pre-set designated period. The unit returning to normal operating temperature will automatically cancel the alarm.

Possible Causes: Evaporator fan not working. Restricted airflow through airduct. Evaporator iced up. Compressor not working. Loss of refrigerant.

Low temperature alarm.

 Will be displayed.

The alarm will sound but can be silenced by pressing any of the buttons and the unit will continue to operate, however it will return after the pre-set designated period. The unit returning to normal operating temperature will automatically cancel the alarm.

Possible Causes: Controller faulty (not switching compressor off). Compressor secondary relay will not de-energise (low temperature models).

Door Open Alarm.

 Will be displayed.

The alarm will sound but can be silenced by pressing.



The display will continue to display the alarm message until cancelled by shutting the door.

If the alarm cannot be cancelled by doing this call your Foster Authorised Service Company.

Possible Causes: Faulty door switch. Door left open for more than 5minutes.

High Pressure Alarm (Condenser probe is not fitted to these models).

 Will be displayed

This alarm relate to the condenser which must be checked and cleaned at regular intervals the frequency being determined by site conditions.

The alarm will sound but can be silenced by pressing any of the buttons and the unit will continue to operate, however it will return after the pre-set designated period. The unit returning to normal operating temperature will automatically cancel the alarm.

Possible Causes: Condenser fan not working. Condenser blocked/ dirty. Condenser obstructed.

Periodic Condenser Clean (not used on these models)

 Will be displayed

This indicates the timed portion of the clean interval has been exceeded and the condenser should be cleaned.

Air Temperature Probe Failure.

 Will be displayed.

The alarm will sound but can be silenced by pressing any button.

There is no further action that can be taken by the user in this instance. During this period the unit will continue to operate but have a reduced performance.

Action: Replace Probe.

Evaporator Temperature Probe Failure. (Automatic Defrost Cabinets Only)

 Will be displayed.

The alarm will sound but can be silenced by pressing any button.

There is no further action that can be taken by the user in this instance. During this period the unit will continue to operate satisfactorily, but this failure will have an effect on the defrost and therefore efficiency if allowed to continue.

Action: Replace Probe.

Information Menu

Pressing and releasing  activates the information menu. From this menu you can display the temperature relating to T1 (air probe), T2 (evaporator probe, if fitted) and T3 (condenser probe, if fitted).

The maximum temperature (THI) and the minimum temperature (TLO) the cabinet has achieved since it was last re-set.



The total operating time of the condenser (CND), since it was last cleaned, and the keyboard status (LOC).

The information to be displayed can be selected sequentially by pressing  repeatedly or scrolling

through the menu using the  or  buttons.

Once selected press  to display the value

Exit from the info menu by pressing  or is automatic after 6 seconds if no buttons are pressed.



To reset the temperature settings recorded in THI and TLO and the hours counted in CND, access the info menu by pressing  to display the value plus  simultaneously for resetting to be completed.

To check the LOC status scroll through to LOC, press  to display status – YES to lock keys. – NO to leave keys accessible.

NOTE: with the keys locked it is not possible to turn the unit off or ON or to check the set point



Parameter Setting and Adjustment

It is strongly advised that before adjusting any Service Parameters a thorough understanding of the following instructions should be obtained.

The parameters are accessed by pressing the following keys in succession  +  +  and keeping them pressed for 5 seconds.

After this period the first parameter 'SCL' will be displayed.



Press button  to pass from one parameter to the next and button  to go back.

Press  to display the value +  or  to change it.

Exit from set up is by pressing  or is automatic if no buttons are pressed for 30 seconds

NOTE:

When receiving a replacement controller the unit will be set with the default settings. Change the settings to those relating to the particular model. After changing parameter 'SCL' from '1' to '2' moving through parameters 'SPL', 'SP', 'FDD', IISL' and 'IISP' you may find that '-or' will be displayed. '-or' indicates that the control setting is out of range.

To get the parameter back into range, for example 'SPL', press  to display the value +  continue pressing both buttons until the display shows the temperature required then release both buttons. Use the same procedure to adjust all of the parameters displaying '-or'.

The **LD2 Controller used on Low temperature Models** has two sets of parameters, the standard parameters plus those that begin with '11'.

With parameter '11SM' set to 'HDD' the controller has the ability to control the cabinet in a more economic manner and still maintain the working temperature.

This will be noticed during the standard parameter settings, economy, the evaporator fan will cycle on and off therefore maintaining the cabinet temperature with the compressor running less frequently.

LD1 – 15E-01FST (00-555847) High Temperature Controller Parameter list

Mnem.	Definition	Min.	Max	Default	Dim.	VALUE
ScL	Readout scale	1°C; 2°C; °F		2	flag	2
SPL	Minimum setpoint [I]	-40	SPH	1	°C	1
SPh	Maximum setpoint [I]	SPL	40	4	°C	4
SP	Setpoint [I]	SPL	SPH	1	°C	1
hYS	Thermostat hysteresis [I]	0.1	10	3	°K	3
crt	Minimum compressor rest time	0	30	1	min.	1
cdc	Compressor regulation with T1 failure	0	10	6	%	6
fPc	Evaporator Fan Timed control	0	4	2	rate	2
dFr	Defrost frequency [I]	0	24	4	rate	4
dLi	Defrost end temperature	-40	40	15	°C	15
dto	Maximum defrost duration	1	120	15	min.	15
dtY	Defrost type	FAN; ELE; GAS		OFF	flag	OFF
drn	Drain down time	0	30	1	min.	1
ddY	Defrost display control	0	60	5	min.	5
ATL	Low alarm differential	-12	0	-5	°C	-5
ATH	High alarm differential	0	12	5	°C	5
Aht	Condenser alarm temperature	0	75	60	°C	60
AHm	Condenser high temperature alarm operation	NON/ALR/STP		NON	flag	NON
Acc	Periodic condenser cleaning	0	52	0	wks	0
Sb	Button (01) enabling	YES	NO	YES	flag	YES
DS	Door switch enabling	YES	NO	YES	flag	YES
cSd	Compressor stop delay from door opening	0	30	1	Min.	1
Ado	Door alarm delay	0	30	5	min.	5
bAu	Manual control enabling	YES	NO	NO	flag	NO
OAU	Auxilliary output control mode	1/0-1/MAN/FAN/DEF/		FAN	flag	FAN
oS1	Probe T1 offset	-12	125	0	°K	0
t2	Function probe T2	NON/DEF/CND		NON	flag	NON
OS2	Probe T2 offset	-12	12	0	°K	0
TLD	Delay for min/max temperature storage	1	30	5	Min.	5
Sim	Display slowdown	0	100	3	flag	3
Adr	Unit address	1	255	1	flag	1

LD2-15E-01FST (00-555848) Low Temperature Controller Parameter List

Mnem.	Definition	Min.	Max	Default	Dim.	VALUES (B)
ScL	Readout scale	1°C; 2°C; °F		1°C	flag	2
SPL	Minimum setpoint [I]	-40	SPH	-25	°C	-21
SPh	Maximum setpoint [I]	SPL	40	-19	°C	-19
SP	Setpoint [I]	SPL	SPH	-19	°C	-19
hYS	Thermostat hysteresis [I]	0.1	10	2	°K	2
crt	Minimum compressor rest time	0	30	1	min.	1
cdc	10 min. run cycle with PF1	0	10	6	%	6
cSd	Compressor Stop delay after door open	0	30	1	min.	1
dFr	Defrost frequency [I]	0	24	3	1/24h	3
dLi	Defrost end temperature	-40	40	20	°C	20
dto	Maximum defrost duration	1	120	20	min.	20
dy	Defrost type	FAN; ELE; GAS		ELE	flag	ELE
drn	Drain down time	0	30	2	min.	2
ddY	Display control during defrost	0	60	10	min.	10
Fid	Fan operation in defrost	YES	NO	NO	flag	NO
Fdd	Evaporator. Fan re-start	-40	40	-50	°C	0
Ftc	Fan timed control [I]	YES	NO	YES	flag	YES
FT1	Fan stop delay (after compressor stop)	0	180	20	Sec,s	20
FT2	Timed fan stop (fan off time)	0	30	1	Min.	1
FT3	Timed fan run (air stir time)	0	30	1	Min.	1
Atl	Low alarm differential	-12	0	-5	°K	-5
Ath	High alarm differential	0	12	5	°K	5
Atd	Temperature alarm delay	0	120	90	min.	90
Ado	Door alarm delay	0	30	5	min.	5
Acc	Periodic condenser cleaning	0	52	0	wks	0
hdS	Sensitivity function Eco->Heavy Duty	1	5	3	flag	3
11SM	2nd parameter set management	NON; MAN; HDD		NON	flag	HDD
11SL	Minimum setpoint [II]	-40	IISH	-21	°C	-21
11SH	Maximum setpoint [II]	IISL	40	-21	°C	-21
11SP	Setpoint [II]	IISL	IISH	-21	°C	-21
11HY	Thermostat hysteresis [II]	0.1	10	3	°K	3
11dF	Defrost frequency [II]	0	24	6	1/24h	6
11Ft	Fan timed control [II]	NO	YES	NO	flag	NO
Sb	Stand By button function	NO	YES	YES	flag	YES
dS	Door switch enabling	YES	NO	YES	flag	YES
oS1	Probe T1 offset	-12	12	0	°K	0
t2	Probe T2 enabling	YES	YES	YES	flag	YES
OS2	Evaporator. Probe offset	-12	12	0	°K	0
tLd	Logging Temp. Delay	1	30	5	min.	5
Sim	Display slowdown	0	100	3	exp.	3
Adr	Unit address	1	255	1	exp.	1

FXT 600 Refrigeration Plug Assembly

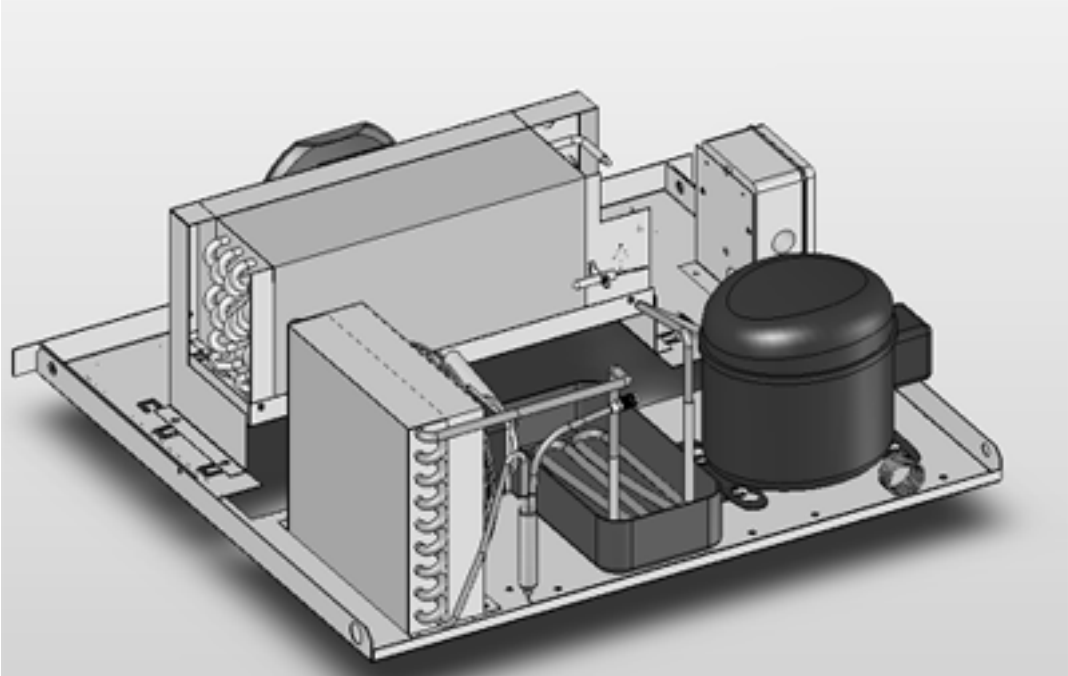

FXT 1350HT Refrigeration Plug Assembly

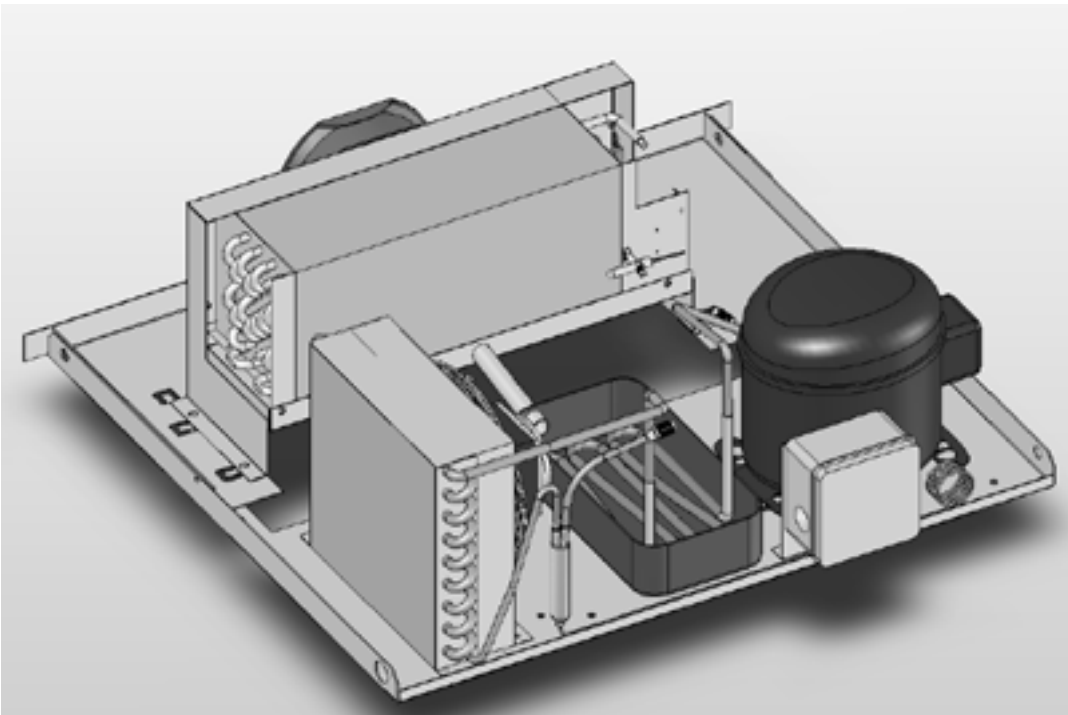

FXT 1350LHT Refrigeration Plug Assembly

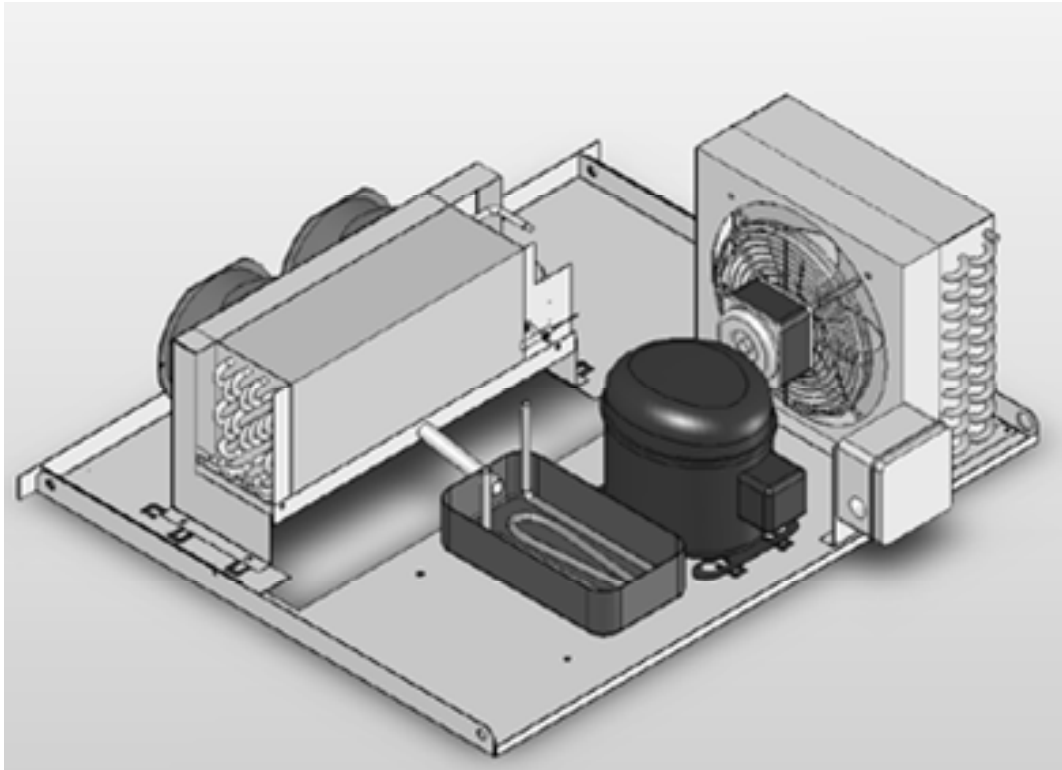

TECHNICAL DATA PRO CABINETS

Model		FXT600H-A	FXT600L-A	FXT1350H-A	FXT1350L-A
Refrigerant		R134a	R404A	R134a	R404A
Refrigerant Charge		380 grms	420 grms	530 grms	550 grms
Compressor		GL80TB	SC15CLX	GP12TB	SC21CLX
Capillary		3mts x 0.042	2.66mts x 0.042	2.80mts x 0.042	2.70mts x 0.047
Expansion Valve for Remote Systems	Valve	TN2-N	TS2NL	N/A	N/A
	Orifice	No 00	No 00	N/A	N/A
Defrost Type		Timed Off Cycle	Electric	Timed Off Cycle	Electric
Voltage		230-1-50	230-1-50	230-1-50	230-1-50
Power Consumption	Watts	510	610	N/A	N/A
	Run Amps	2.6	3.2	3.7	5.1
Fuse Rating		10 Amp	10 Amp	10 Amp	10 Amp

Spare Parts List

ITEM	DESCRIPTION	PART NUMBER	MODEL
Compressor	GL80TB	00-555112	FXT 600H
Compressor	SC15CLX 230/50/1	00-554943	FXT 600L
Compressor	GP12TB R134 HBP	00-555666	FXT1350H
Compressor	SC21CLX 230/1/50	00-554989	FXT1350L
Condenser Fan Motor	Grid Mount 5W	15470032	FXT 600H
Condenser Fan Motor	Grid Mount 16W	15470027	FXT 600L- FXT1350H - FXT1350L
Condenser Coil		00-554932	FXT 600H
Condenser Coil		00-878509-01	FXT 600L
Condenser Coil		00-878506-01	FXT1350H
Condenser Coil		00-878508-01	FXT1350L
Drier	1/4 Double Entry 1/4 out R134A	15480908	All Models
Capillary	3mts x 0.042		FXT 600H
Capillary	2.660mts X 0.042		FXT 600L
Capillary	2.800mts x 0.042		FXT1350H
Capillary	2.700mts x 0.047		FXT1350L
Vaporiser Tray	258X136X60.5mm	15271004	All Models
Evaporator Coil	Coil 015158 Xtra	01-257437-01	FXT 600H
Evaporator Coil	Coil 015158 Xtra	01-257437-01	FXT 600L- FXT1350H
Evaporator Fan Motor	Fulltech UF15PC23-BTH 29W	00-555871	All Models
Defrost Heater	Heater Rod 500W 230V	01-252379-01	FXT 600L - FXT1350L
Controller	LAE LD1-15 (HT)	00-555847	FXT 600H-FXT1350H
Controller	LAE LD2-15E-01FST (LT)	00-555848	FXT 600L- FXT1350L
Air Probe	1.5M SN2K15P1	00-555870	All Models
Evaporator Probe	1.5M SN2K15P2	00-555869	FXT 600L - FXT1350L
Door Switch Magnet	Circular	00-555828	All Models
Circular Door Switch	Reed Type	00-555829	All Models
Magnetic Half Door Gasket	623x747	01-231704-01	All Half Door Models
Magnetic Full Door Gasket	623x1541	01-231709-01	All Full Door Models
Miniature Rocker Switch		00-554774	Models With Glass Doors
Lamp Transformer	230V TO 12V AC	00-555933	All Models
Lamp	12V 20W MR11 Type	00-555934	All Models
Lamp Fitting	For 12V MR11 type	00-555935	All Models

Wiring Diagram FXT600H & 1350H Integral Configuration

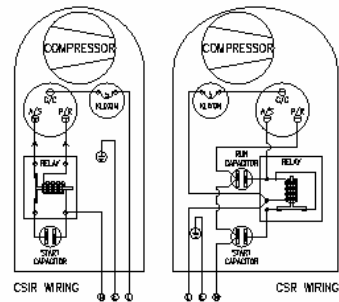
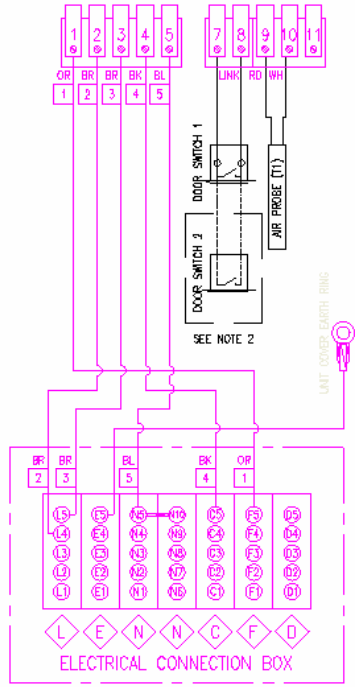
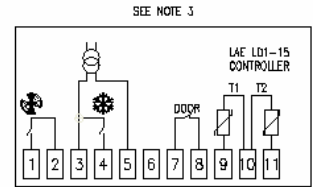
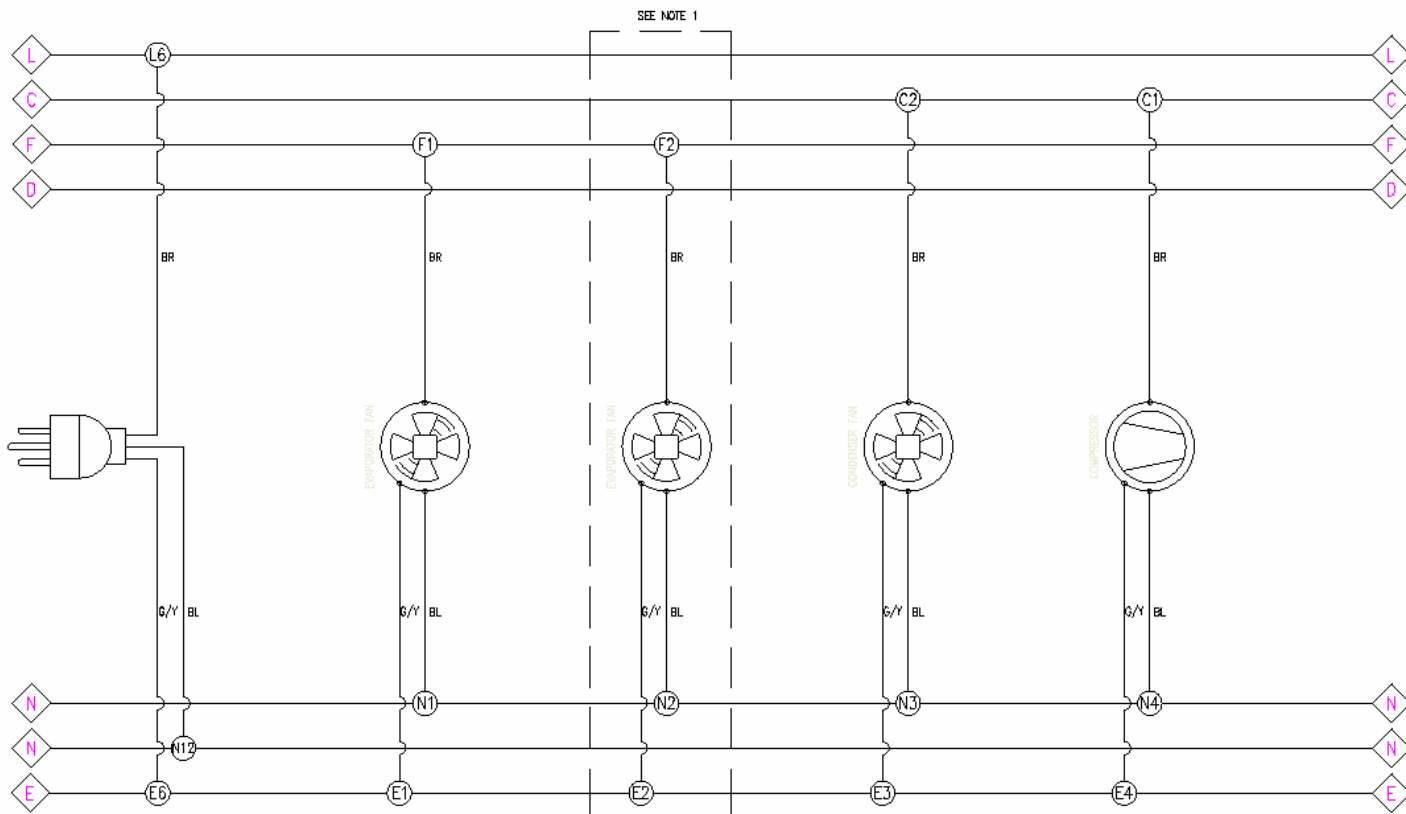

CUSTOMER COPY

- NOTES:**
1. SECOND EVAPORATOR FAN ON 1350 MODELS ONLY.
 2. DOOR SWITCH 2 ONLY FITTED ON DOUBLE DOOR MODELS, WIRED IN SERIES WITH DOOR SWITCH 1.
 3. CONTROLLER CONFIGURED FOR OFF CYCLE DEFROST.
 4. ALL CABLE 1.0mm² UNLESS OTHERWISE STATED.
 5. PLUG & SOCKET CONNECTION —

ALL CABLES 1mm UNLESS STATED

CABLE COLOUR CODE -

BR - BROWN	BK - BLACK	PK - PINK
BL - BLUE	WH - WHITE	BG - BEIGE
G/Y - GREEN/YELLOW	GY - GREY	GR - GREEN
RD - RED	VT - VIOLET	CL - CLEAR
OR - ORANGE		

01.04		ndcode	26/03/2007
REV	DESCRIPTION	BY	DATE
	WIRING DIAGRAM		
	FXT 600H & 1350H	Drawing No.:	01-258290-00-01.04
	INTEGRAL CONFIGURATION	Date:	04/12/2006
		Drawn:	mgreenhalgh
		Approved:	
		Sheet	of

Wiring Diagram FXT600L & 1350L Integral Configuration

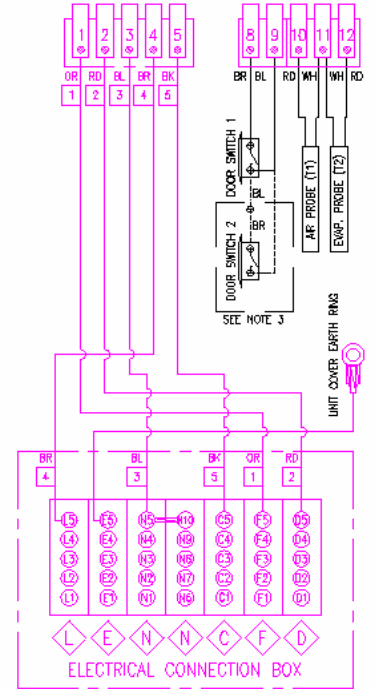
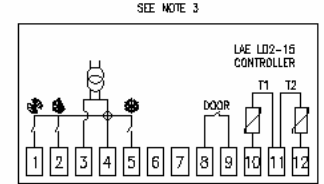
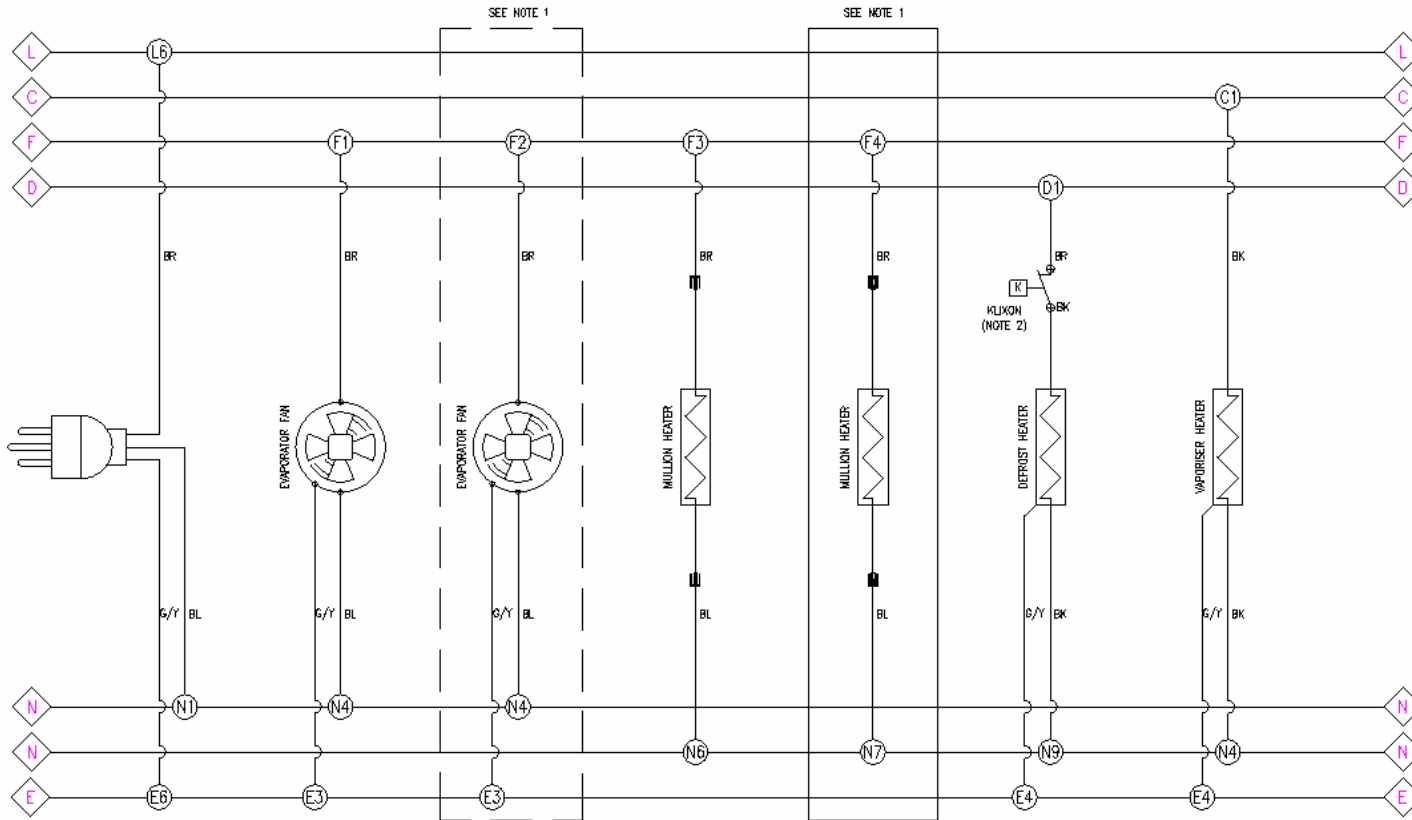

SECOND EVAPORATOR FAN AND MULLION HEATER FITTED ON 1350 MODELS ONLY.
 KLIXON 2 NORMALLY CLOSED TYPE - OPENS 20°C / CLOSES 5°C FITTED TO EVAPORATOR COOL END PLATE.
 DOOR SWITCH 2 ONLY FITTED ON DOUBLE DOOR MODELS, WIRED IN SERIES WITH DOOR SWITCH 1.
 CONTROLLER CONFIGURED FOR ELECTRIC DEFOST.
 ALL CABLE 1.0mm² UNLESS OTHERWISE STATED.
 PLUG & SOCKET CONNECTION -

CABLE COLOUR CODE:
 BR - BROWN RD - RED GY - GREY
 BL - BLUE BK - BLACK VT - VIOLET
 G/Y - GREEN / YELLOW WH - WHITE OR - ORANGE
 (ALL EARTH WIRING TO BE GREEN/YELLOW)

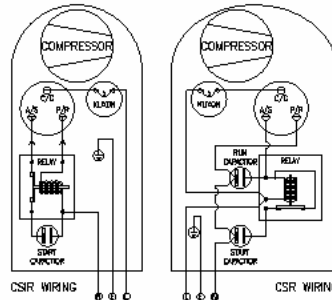

CUSTOMER COPY

ALL CABLES 1mm UNLESS STATED

CABLE COLOUR CODE -
 BR - BROWN BK - BLACK PK - PINK
 BL - BLUE WH - WHITE BG - BEIGE
 G/Y - GREEN/YELLOW GY - GREY GR - GREEN
 RD - RED VT - VIOLET CL - CLEAR
 OR - ORANGE

01.02	DESCRIPTION	ndade	25/03/2007
REV		BY	DATE
WIRING DIAGRAM		Drawing No.:	01-258909-00-01.02
FXT 600L & 1350L		Date:	25/03/2007
REMOTE CONFIGURATION		Drawn:	ndade
		Approved:	
		Sheet	of

Wiring Diagram FXT600H & 1350H Remote Configuration

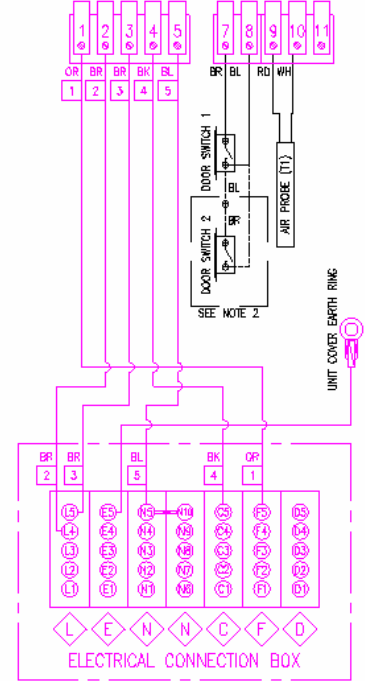
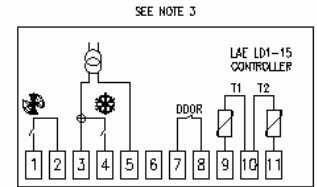
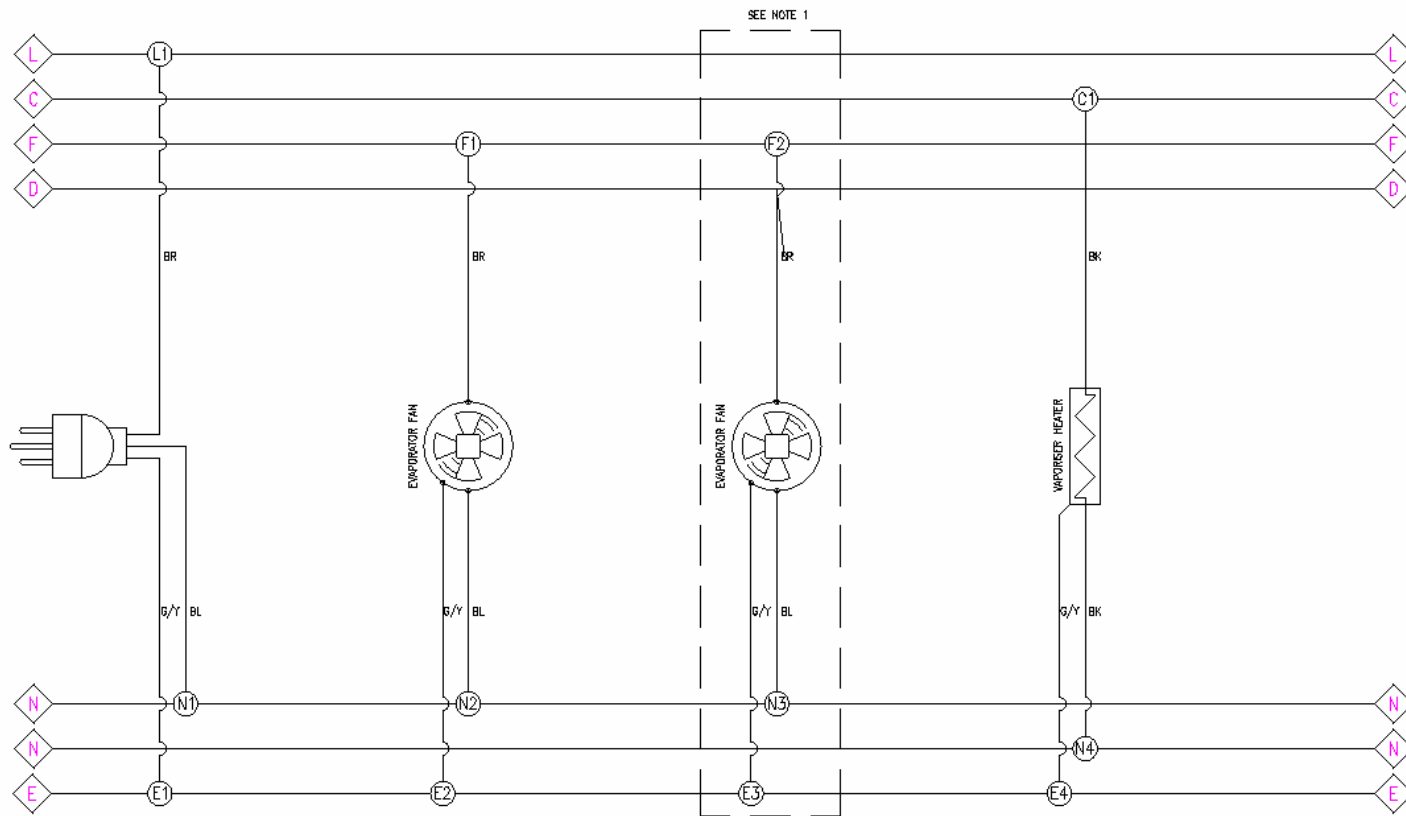

- NOTES:**
- SECOND EVAPORATOR FAN ON 1350 MODELS ONLY.
 - DOOR SWITCH 2 ONLY FITTED ON DOUBLE DOOR MODELS, WIRED IN SERIES WITH DOOR SWITCH 1.
 - CONTROLLER CONFIGURED FOR OFF CYCLE DEFOST.
 - ALL CABLE 1.0mm² UNLESS OTHERWISE STATED.
 - PLUG & SOCKET CONNECTION
 - CABLE COLOUR CODE:

BR - BROWN	RD - RED	GY - GREY
BL - BLUE	BK - BLACK	VT - VIOLET
G/Y - GREEN / YELLOW	WH - WHITE	OR - ORANGE

 (ALL EARTH WIRING TO BE GREEN/YELLOW)

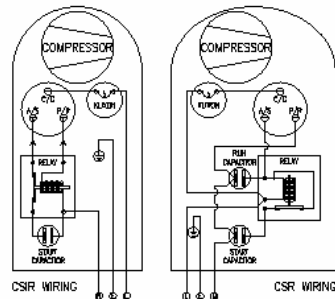

CUSTOMER COPY

- ALL CABLES 1m UNLESS STATED
- CABLE COLOUR CODE -
- | | | |
|--------------------|-------------|------------|
| BR - BROWN | BK - BLACK | PK - PINK |
| BL - BLUE | WH - WHITE | BG - BEIGE |
| G/Y - GREEN/YELLOW | GY - GREY | GR - GREEN |
| RD - RED | VT - VIOLET | CL - CLEAR |
| OR - ORANGE | | |

01.02		ndade	26/03/2007
REV	DESCRIPTION	BY	DATE
	WIRING DIAGRAM		
	FXT 600H & 1350H	Drawing No.:	01-258908-00-01.02
	REMOTE CONFIGURATION	Date:	26/03/2007
		Drawn:	ndade
		Approved:	
		Sheet	of

Wiring Diagram FXT600L & 1350L Remote Configuration

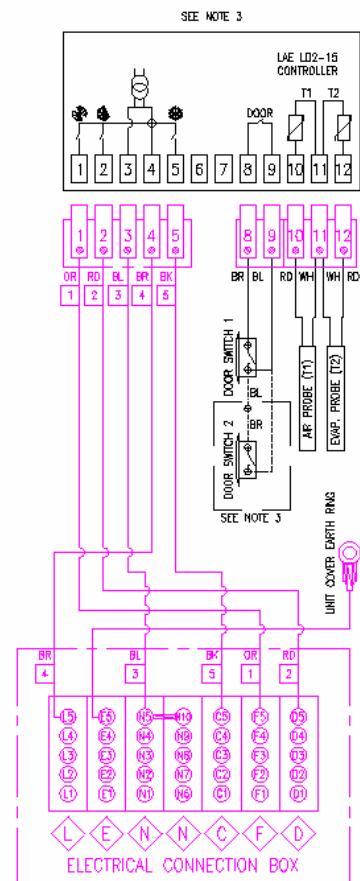
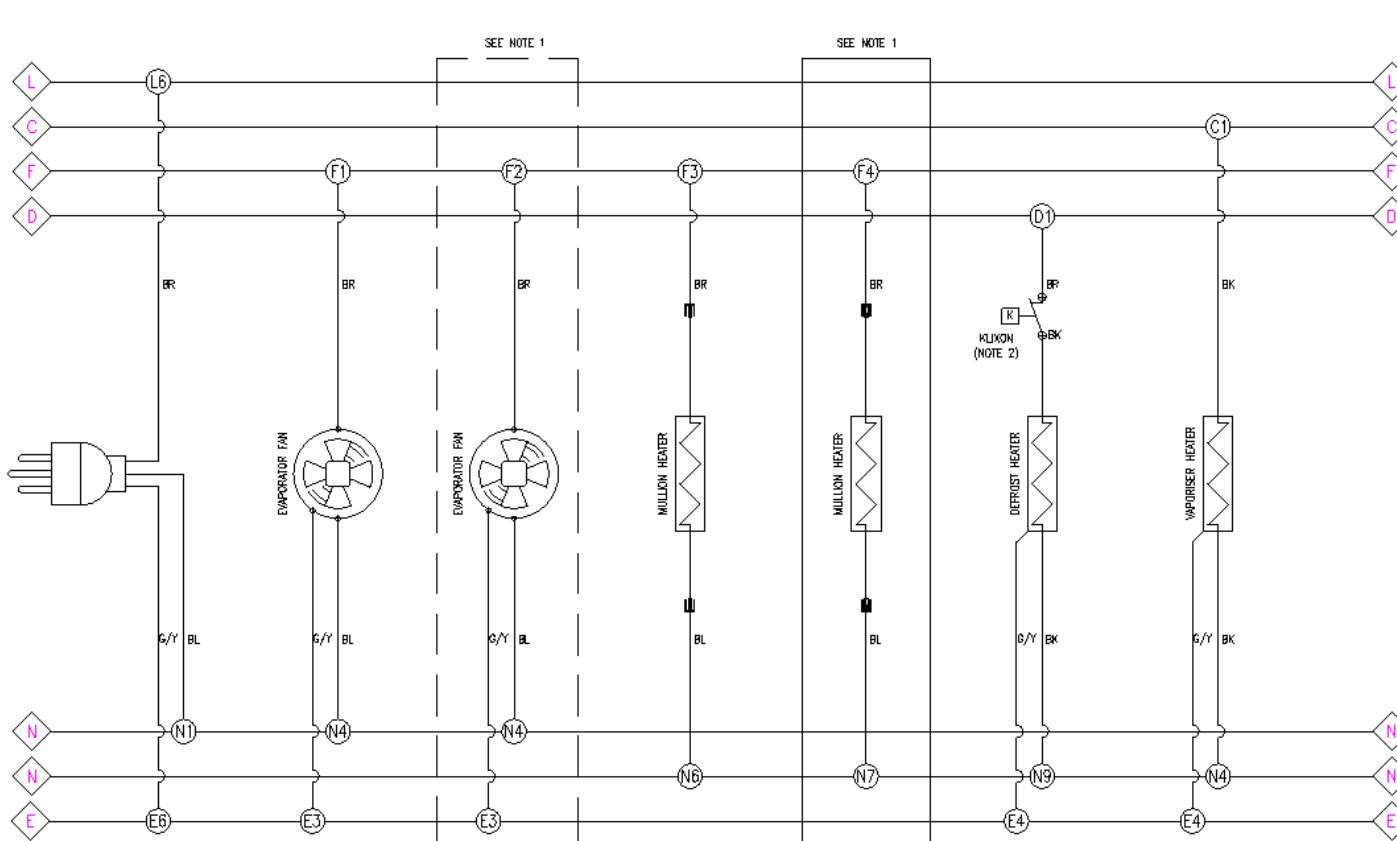

SECOND EVAPORATOR FAN AND MULLION HEATER FITTED ON 1350 MODELS ONLY.
 KLIXON 2 NORMALLY CLOSED TYPE - OPENS 20°C / CLOSES 5°C FITTED TO EVAPORATOR COOL END PLATE.
 DOOR SWITCH 2 ONLY FITTED ON DOUBLE DOOR MODELS, WIRED IN SERIES WITH DOOR SWITCH 1.
 CONTROLLER CONFIGURED FOR ELECTRIC DEFROST.
 ALL CABLE 1.0mm² UNLESS OTHERWISE STATED.
 PLUG & SOCKET CONNECTION —

CABLE COLOUR CODE:
 BR - BROWN RD - RED GY - GREY
 BL - BLUE BK - BLACK VT - VIOLET
 G/Y - GREEN / YELLOW WH - WHITE OR - ORANGE
 (ALL EARTH WIRING TO BE GREEN/YELLOW)

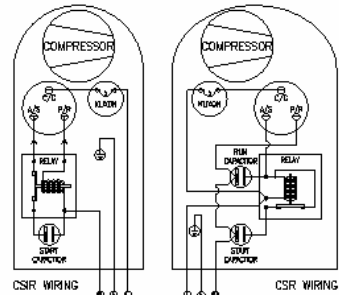

CUSTOMER COPY

ALL CABLES 1mm UNLESS STATED

CABLE COLOUR CODE -
 BR - BROWN BK - BLACK PK - PINK
 BL - BLUE WH - WHITE BG - BEIGE
 G/Y - GREEN/YELLOW GY - GREY GR - GREEN
 RD - RED VT - VIOLET CL - CLEAR
 OR - ORANGE

01.02		ndade	25/03/2007
REV	DESCRIPTION	BY	DATE
	WIRING DIAGRAM		
	FXT 600L & 1350L	Drawing No.:	01-258909-00-01.02
	REMOTE CONFIGURATION	Date:	25/03/2007
		Drawn:	ndade
		Approved:	
		Sheet	of

Wiring Diagram FXT600H Integral Configuration with Lights

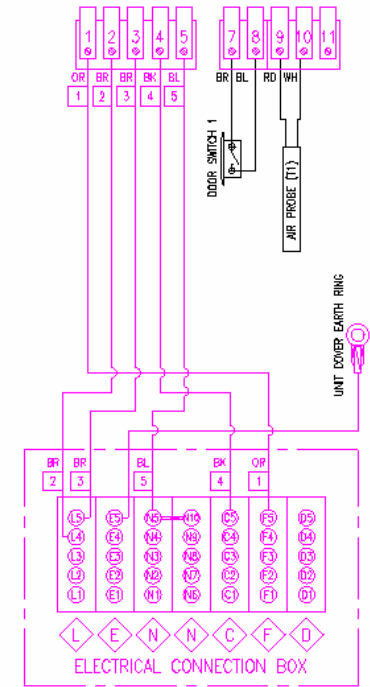
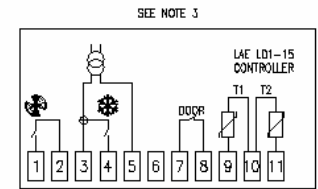
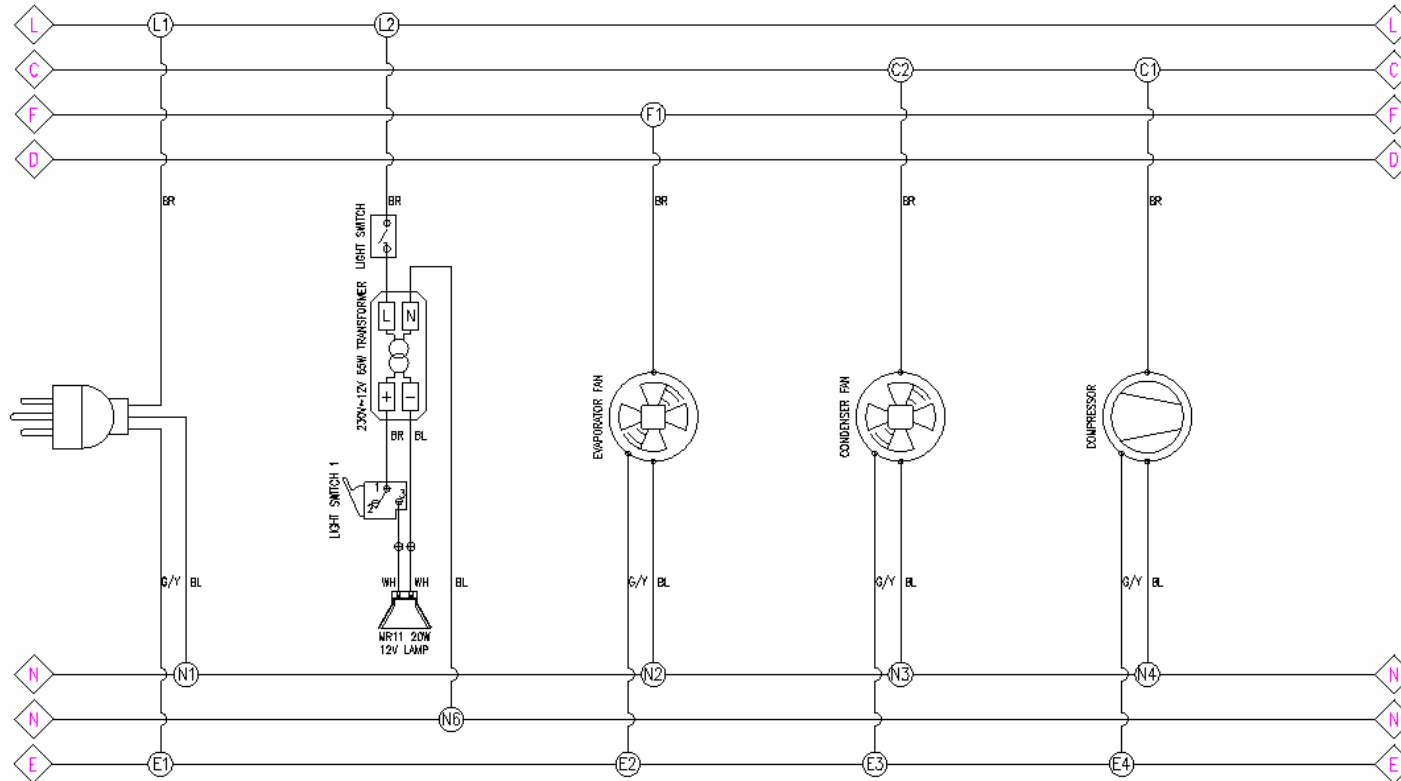

NOTES:

1. SECOND EVAPORATOR FAN ON 1350 MODELS ONLY.
2. DOOR SWITCH 2 ONLY FITTED ON DOUBLE DOOR MODELS. WIRED IN SERIES WITH DOOR SWITCH 1.
3. CONTROLLER CONFIGURED FOR OFF CYCLE DEFOST.
4. ALL CABLE 1.0mm² UNLESS OTHERWISE STATED.
5. PLUG & SOCKET CONNECTION
6. CABLE COLOUR CODE:

BR - BROWN	RD - RED	G/Y - GREY
BL - BLUE	BK - BLACK	VT - VIOLET
G/Y - GREEN / YELLOW	WH - WHITE	OR - ORANGE
RD - RED	GY - GREY	GR - GREEN
OR - ORANGE	VT - VIOLET	CL - CLEAR

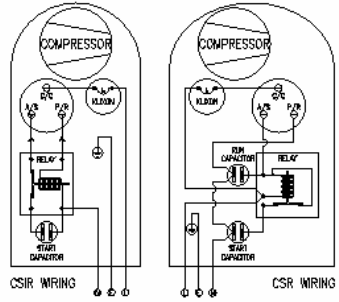

CUSTOMER COPY

ALL CABLES 1mm UNLESS STATED

CABLE COLOUR CODE -

BR - BROWN	BK - BLACK	PK - PINK
BL - BLUE	WH - WHITE	BG - BEIGE
G/Y - GREEN/YELLOW	GY - GREY	GR - GREEN
RD - RED	VT - VIOLET	CL - CLEAR
OR - ORANGE		

01.02		ndade	26/03/2007
REV	DESCRIPTION	BY	DATE
	WIRING DIAGRAM		
	FXT 600H	Drawing No.:	01-258914-00-01.02
	INTERNAL CONFIGURATION	Date:	26/03/2007
	WITH UNIT COVER LIGHT	Drawn:	ndade
		Approved:	
		Sheet	of

Wiring Diagram FXT600L Integral Configuration with Lights

SEE NOTE 3

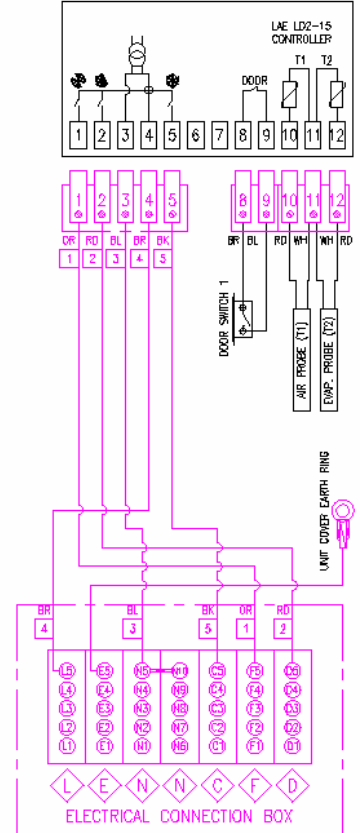
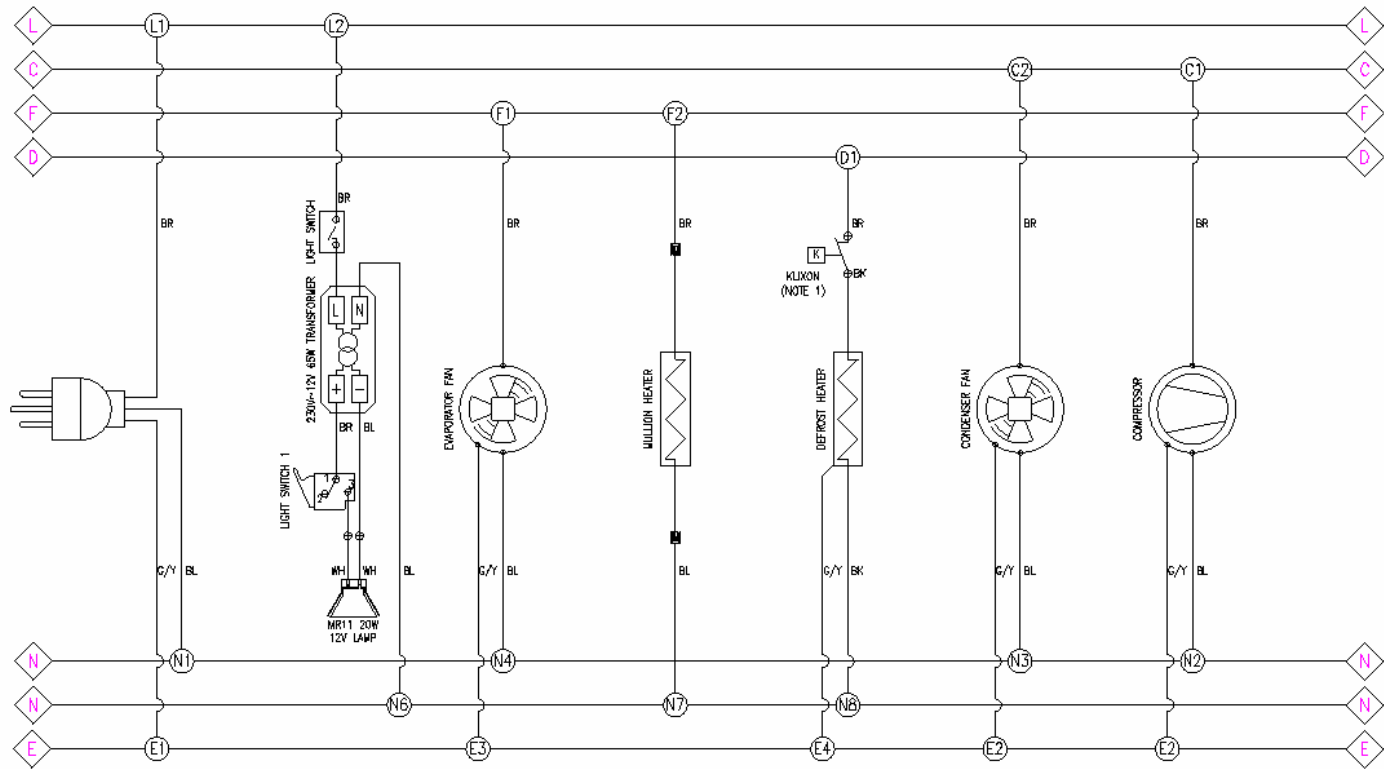

NOTES:

1. KLIXON 2 NORMALLY CLOSED TYPE - OPENS 20°C / CLOSES 5°C FITTED TO EVAPORATOR COIL END PLATE.
2. CONTROLLER CONFIGURED FOR ELECTRIC DEFROST.
3. ALL CABLE 1.0mm² UNLESS OTHERWISE STATED.
4. PLUG & SOCKET CONNECTION

CABLE COLOUR CODE:

BR - BROWN	RD - RED	GY - GREY
BL - BLUE	BK - BLACK	VT - VIOLET
G/Y - GREEN / YELLOW	WH - WHITE	OR - ORANGE

(ALL EARTH WIRING TO BE GREEN/YELLOW)

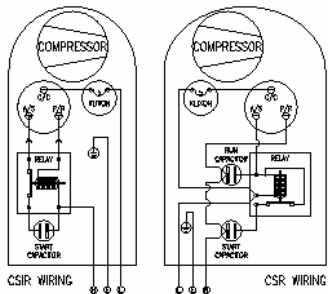

CUSTOMER COPY

ALL CABLES 1mm UNLESS STATED

CABLE COLOUR CODE -

BR - BROWN	BK - BLACK	PK - PINK
BL - BLUE	WH - WHITE	BG - BEIGE
G/Y - GREEN/YELLOW	GY - GREY	GR - GREEN
RD - RED	VT - VIOLET	CL - CLEAR
OR - ORANGE		

01.02		ndode	26/03/2007
REV	DESCRIPTION	BY	DATE
	WIRING DIAGRAM		
	FXT 600L	Drawing No.:	01-258915-00-01.02
	INTEGRAL CONFIGURATION	Date:	26/03/2007
	WITH UNIT COVER LIGHT	Approved:	
		Sheet	of

Wiring Diagram FXT1350H Integral Configuration with Lights

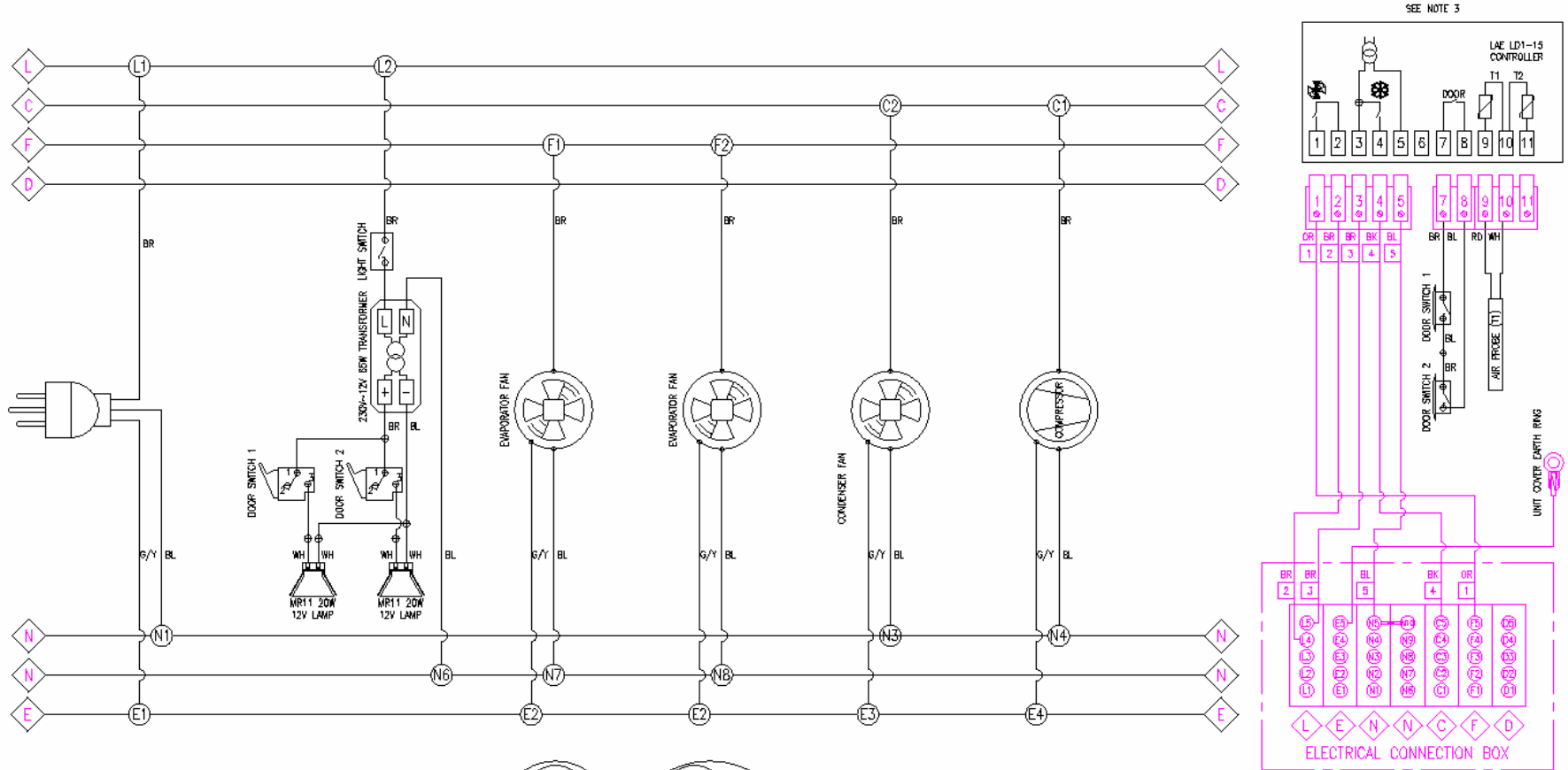

NOTES:

1. SECOND EVAPORATOR FAN ON 1350 MODELS ONLY.
2. DOOR SWITCH 2 ONLY FITTED ON DOUBLE DOOR MODELS, WIRED IN SERIES WITH DOOR SWITCH 1.
3. CONTROLLER CONFIGURED FOR OFF CYCLE DEFROST.
4. ALL CABLE 1.0mm² UNLESS OTHERWISE STATED.
5. PLUG & SOCKET CONNECTION
6. CABLE COLOUR CODE:

BR - BROWN	RD - RED	GY - GREY
BL - BLUE	BK - BLACK	VT - VIOLET
G/Y - GREEN / YELLOW	WH - WHITE	OR - ORANGE

 (ALL EARTH WIRING TO BE GREEN/YELLOW)

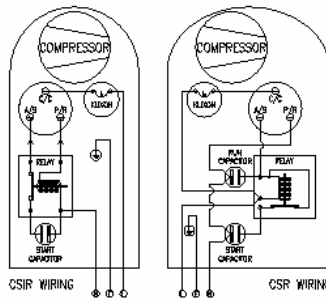

CUSTOMER COPY

ALL CABLES 1mm² UNLESS STATED

CABLE COLOUR CODE -

BR - BROWN	BK - BLACK	PK - PINK
BL - BLUE	WH - WHITE	IG - BEIGE
G/Y - GREEN/YELLOW	RD - RED	GR - GREEN
RD - RED	VT - VIOLET	CL - CLEAR

01.02		ndade	26/03/2007
REV	DESCRIPTION	BY	DATE
	WIRING DIAGRAM FXT 1350H	Drawing No. : 01-258915-00-01.02	
	INTEGRAL CONFIGURATION	Date : 26/03/2007	Drawn : ndade
	WITH UNIT COVER LIGHTS	Approved :	Sheet of

Wiring Diagram FXT1350L Integral Configuration with Lights

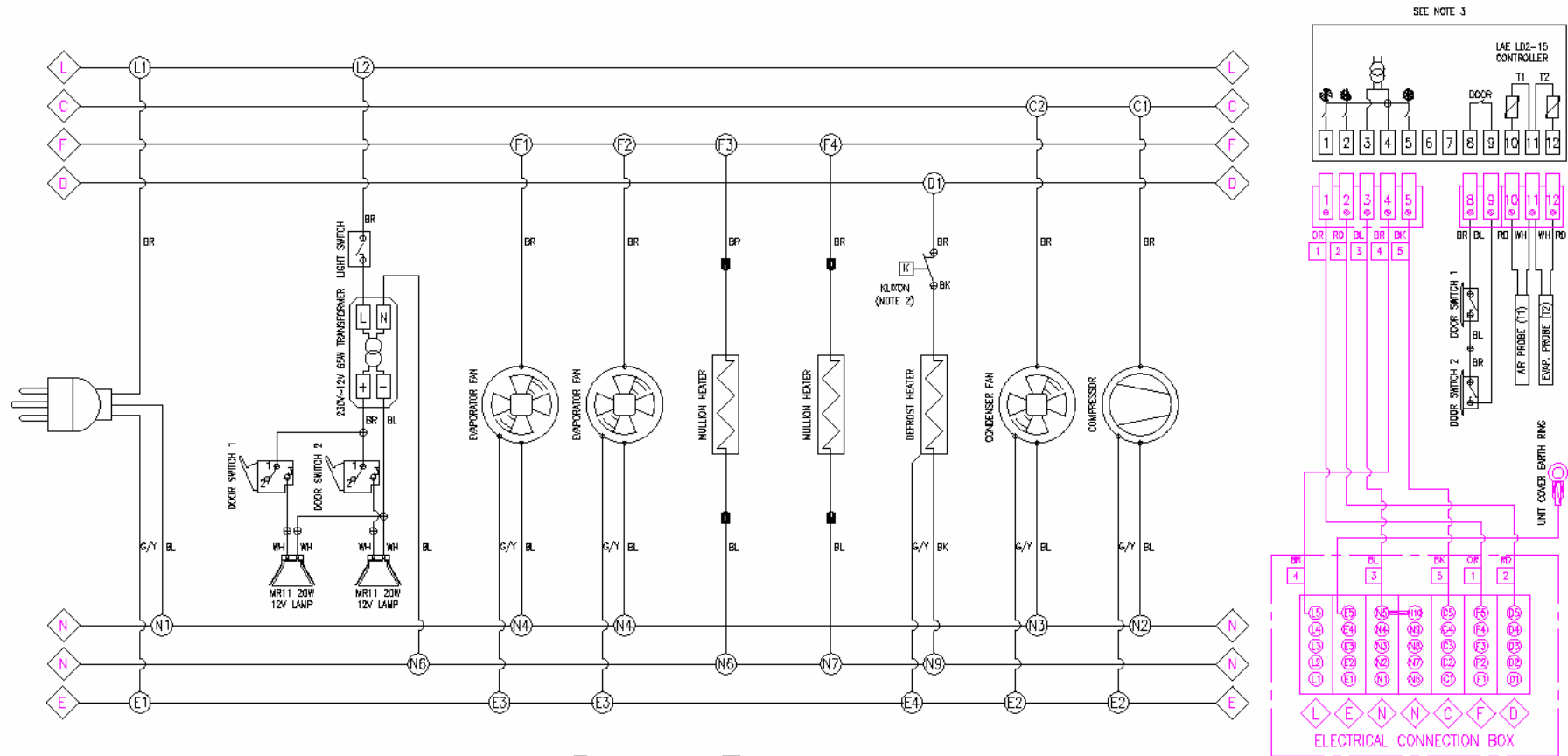

NOTES:

1. SECOND EVAPORATOR FAN AND MULLION HEATER FITTED ON 1350 MODELS ONLY.
2. KLXON 2 NORMALLY CLOSED TYPE - OPENS 20% / CLOSSES 5% FITTED TO EVAPORATOR COIL END PLATE.
3. DOOR SWITCH 2 ONLY FITTED ON DOORABLE DOOR MODELS. WIRED IN SERIES WITH DOOR SWITCH 1.
4. CONTROLLER CONFIGURED FOR ELECTRIC DEFROST.
5. ALL CABLE 1.0mm² UNLESS OTHERWISE STATED.
6. PLUG & SOCKET CONNECTION -

CABLE COLOUR CODE:

BR - BROWN	RD - RED	GY - GREY
BL - BLUE	BK - BLACK	VT - VIOLET
G/Y - GREEN / YELLOW	WH - WHITE	OR - ORANGE

(ALL EARTH WIRING TO BE GREEN/YELLOW)

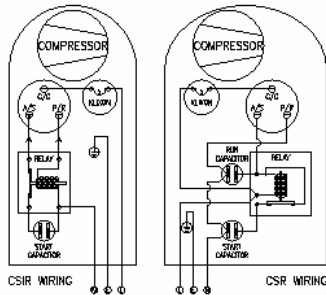

CUSTOMER COPY

ALL CABLES 1mm UNLESS STATED

BR - BROWN	BK - BLACK	PK - PINK
BL - BLUE	IG - BEIGE	GR - GREEN
G/Y - GREEN/YELLOW	GY - GREY	GR - GREEN
RD - RED	VT - VIOLET	CL - CLEAR
OR - ORANGE		

01.02		ndade	26/03/2007
REV	DESCRIPTION	BY	DATE

WIRING DIAGRAM	Drawing No. : 01-258917-00-01.02
FXT 1350L	Date : 26/03/2007
INTEGRAL CONFIGURATION	Approved :
WITH UNIT COVER LIGHTS	Sheet of

Wiring Diagram FXT600H Remote Configuration with Lights

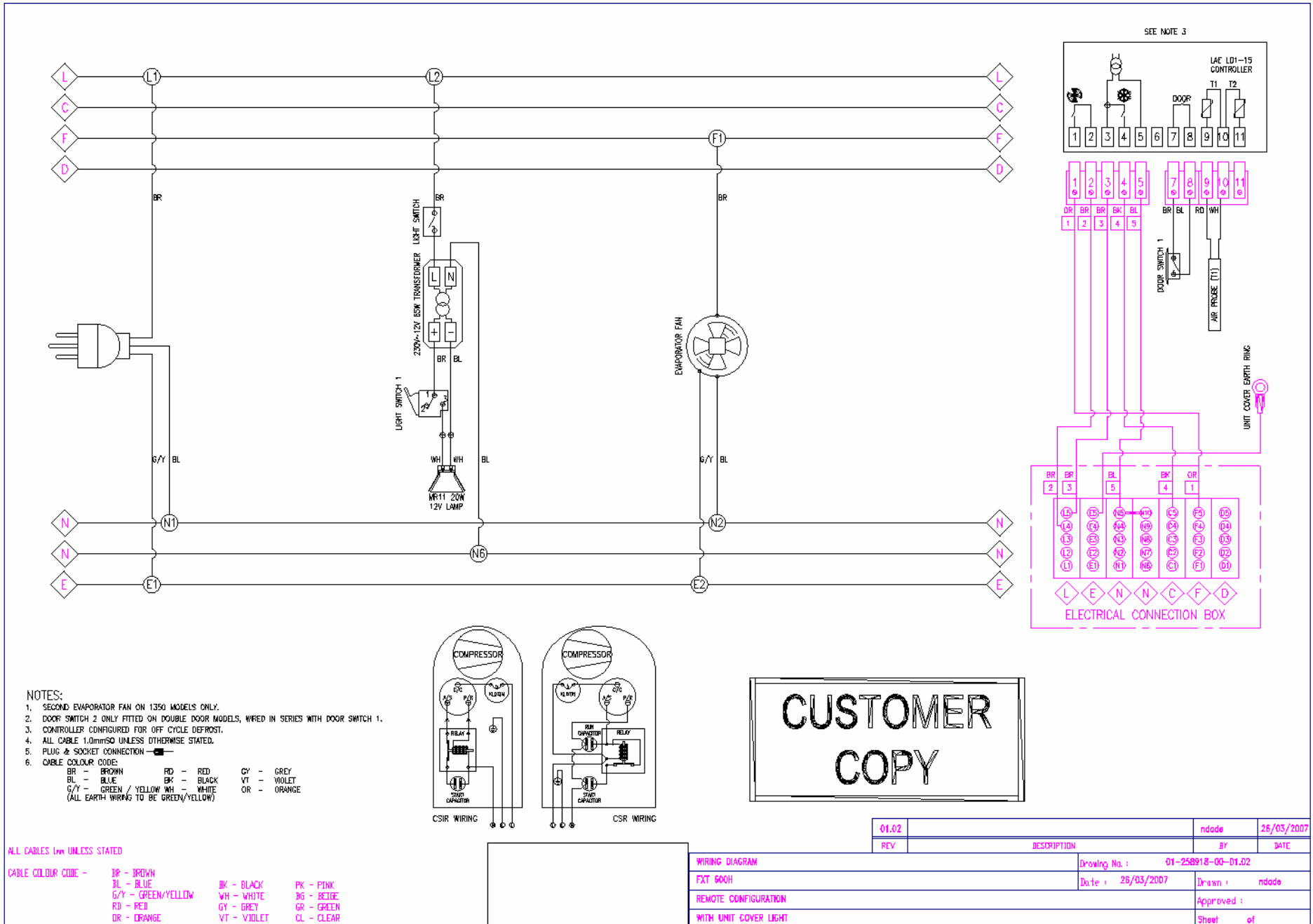

01.02		ndade	26/03/2007
REV	DESCRIPTION	BY	DATE
	WIRING DIAGRAM	Drawing No.:	01-258918-00-01.02
	FXT 600H	Date:	26/03/2007
	REMOTE CONFIGURATION	Drawn:	ndade
	WITH UNIT COVER LIGHT	Approved:	
		Sheet	of

Wiring Diagram FXT600L Remote Configuration with Lights

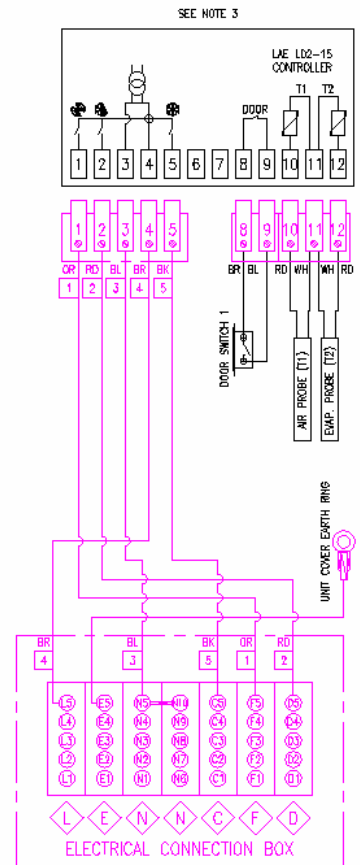
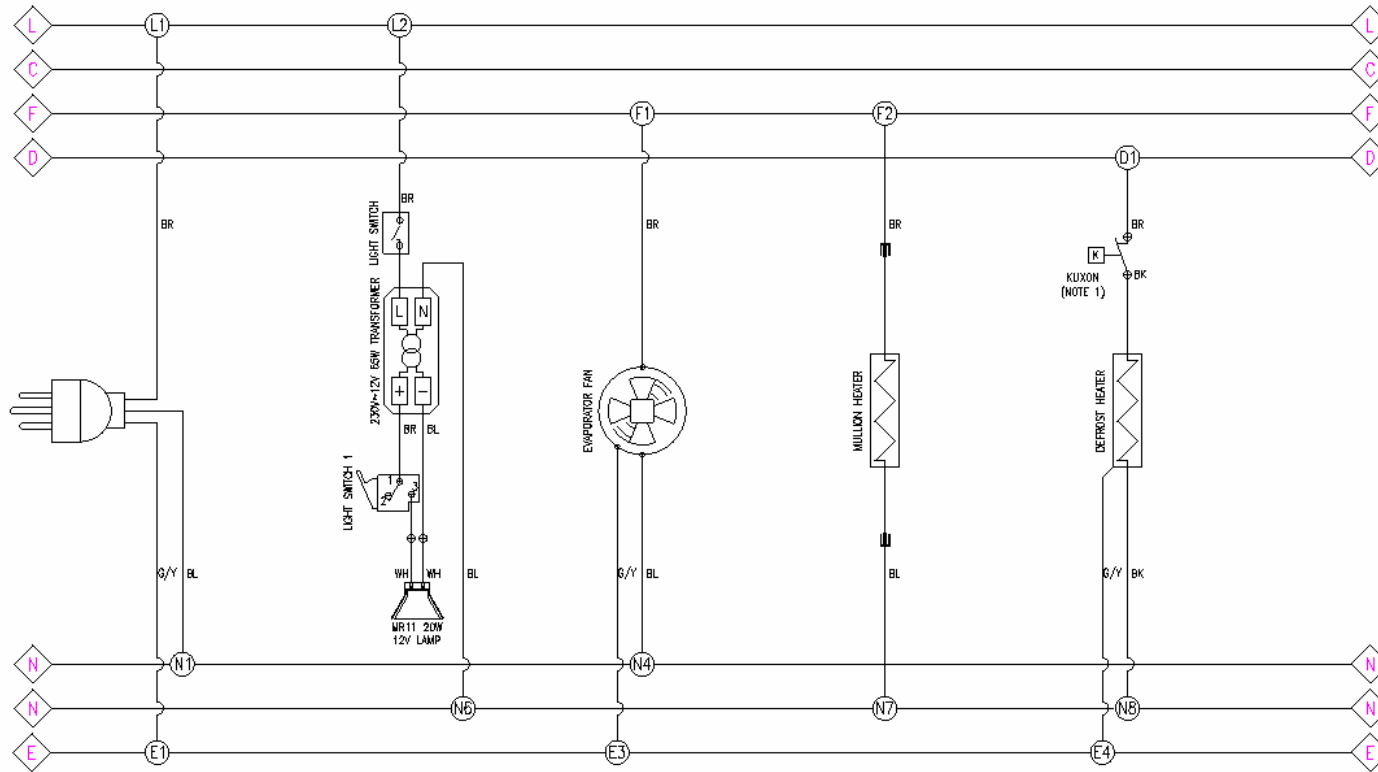

NOTES:

1. KUXON 2 NORMALLY CLOSED TYPE - OPENS 20°C / CLOSES 5°C FITTED TO EVAPORATOR COIL END PLATE.
2. CONTROLLER CONFIGURED FOR ELECTRIC DEFROST.
3. ALL CABLE 1.0mm² UNLESS OTHERWISE STATED.
4. PLUG & SOCKET CONNECTION -

CABLE COLOUR CODE:

BR - BROWN RD - RED GY - GREY
 BL - BLUE BK - BLACK YV - VIOLET
 G/Y - GREEN / YELLOW WH - WHITE OR - ORANGE
 (ALL EARTH WIRING TO BE GREEN/YELLOW)

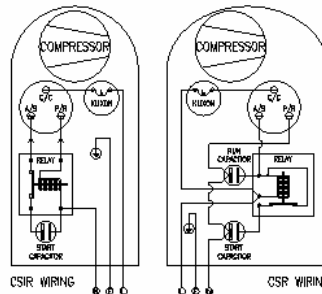

CUSTOMER COPY

ALL CABLES 1mm UNLESS STATED

CABLE COLOUR CODE -

BR - BROWN BK - BLACK PK - PINK
 BL - BLUE WH - WHITE JG - BEIGE
 G/Y - GREEN/YELLOW GY - GREY GR - GREEN
 RD - RED DR - ORANGE VT - VIOLET CL - CLEAR

01.02		ndade	26/03/2007
REV	DESCRIPTION	BY	DATE
	WIRING DIAGRAM		
	FXT 600L	Drawing No.:	01-258919-00-01.02
	REMOTE CONFIGURATION	Date:	26/03/2007
	WITH UNIT COVER LIGHT	Approved:	
		Sheet	of

Wiring Diagram FXT1350H Remote Configuration with Lights

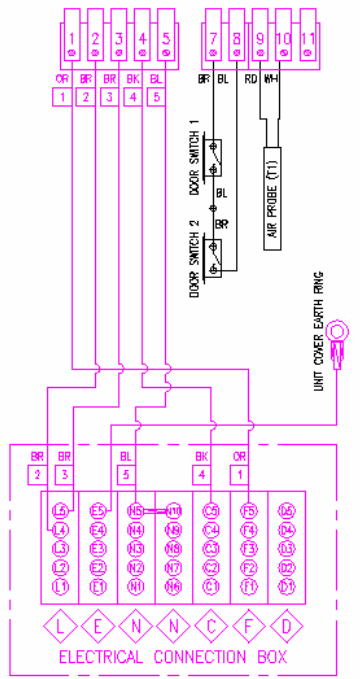
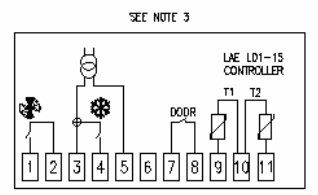
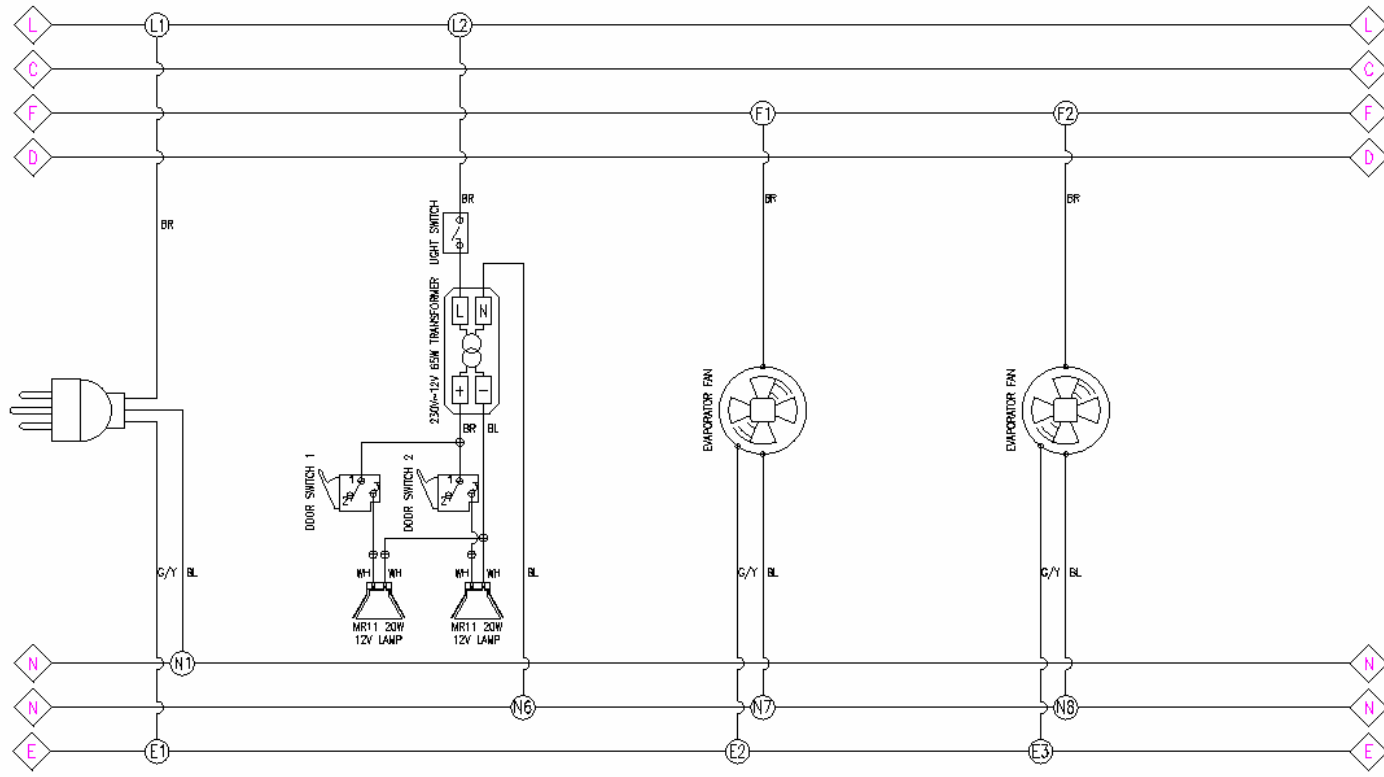

- NOTES:**
1. SECOND EVAPORATOR FAN ON 1350 MODELS ONLY.
 2. DOOR SWITCH 2 ONLY FITTED ON DOUBLE DOOR MODELS, WIRED IN SERIES WITH DOOR SWITCH 1.
 3. CONTROLLER CONFIGURED FOR OFF CYCLE DEFROST.
 4. ALL CABLE 1.0mm² UNLESS OTHERWISE STATED.
 5. PLUG & SOCKET CONNECTION
 6. CABLE COLOUR CODE:

BR - BROWN	RD - RED	GY - GREY
BL - BLUE	BK - BLACK	VT - VIOLET
G/Y - GREEN/YELLOW	WH - WHITE	OR - ORANGE

 (ALL EARTH WIRING TO BE GREEN/YELLOW)

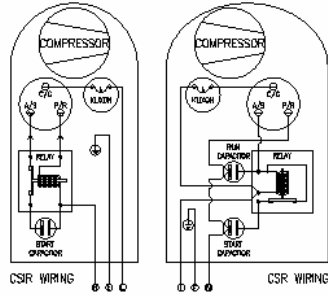

CUSTOMER COPY

ALL CABLES 1mm UNLESS STATED

- CABLE COLOUR CODE -**
- | | | |
|--------------------|-------------|------------|
| BR - BROWN | BK - BLACK | PK - PINK |
| BL - BLUE | WH - WHITE | BG - BEIGE |
| G/Y - GREEN/YELLOW | GY - GREY | GR - GREEN |
| RD - RED | VT - VIOLET | CL - CLEAR |
| OR - ORANGE | | |

01.02		ndode	25/03/2007
REV	DESCRIPTION	BY	DATE
	WIRING DIAGRAM		
	FXT 1350H	Drawing No.:	01-258920-00-01.02
	REMOTE CONFIGURATION	Date:	25/03/2007
	WITH UNIT COVER LIGHTS	Approved:	
		Sheet	of

Wiring Diagram FXT1350L Remote Configuration with Lights

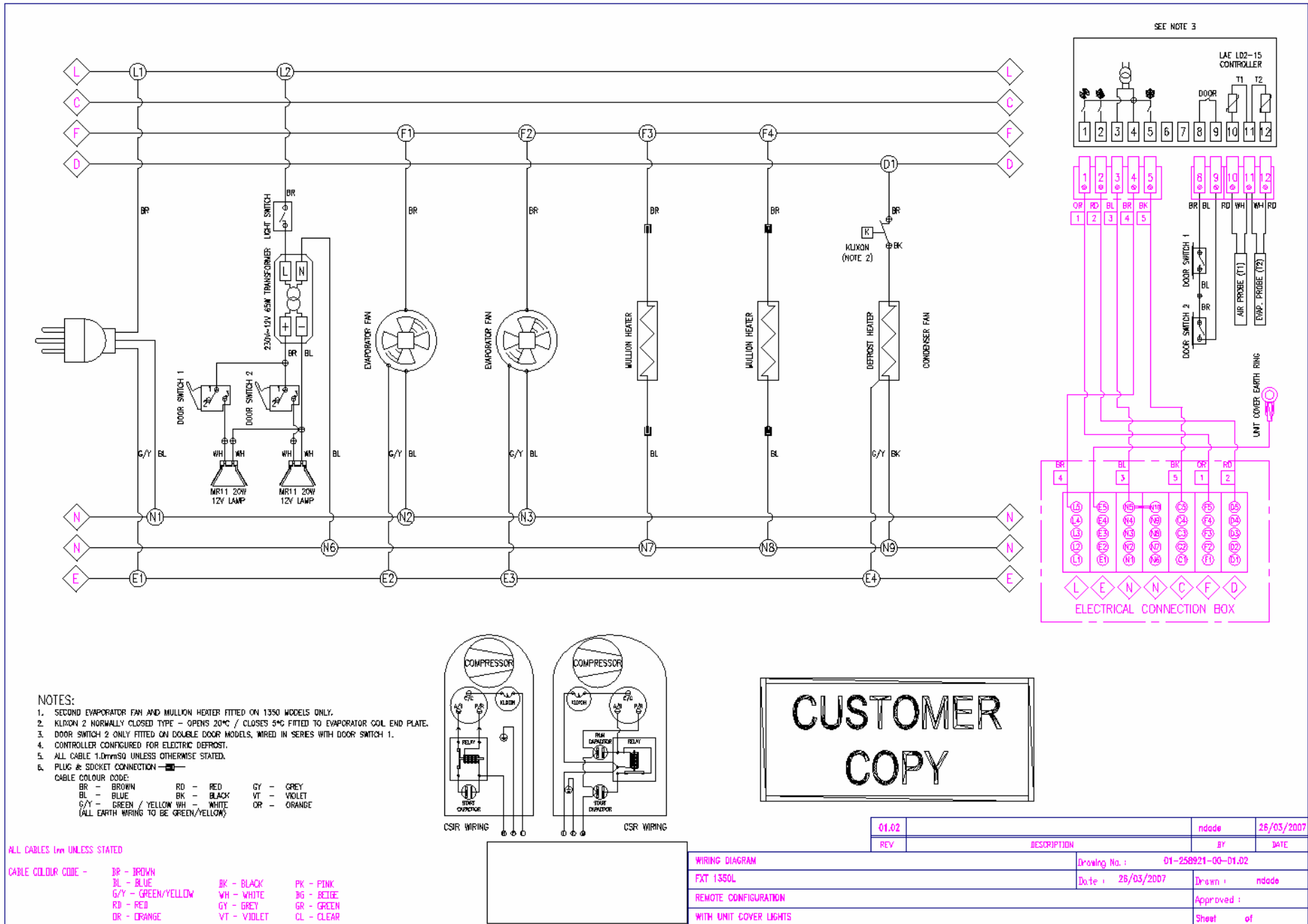



Foster European Operations

France

Foster Refrigerator France SA

Tel: (33) 01 34 30 22 22. Fax: (33) 01 30 37 68 74.

Email: commercial@fosterfrance.com

Germany

Foster Refrigerator Gmbh,

Tel: (49) 2333 839375. Fax (49) 2333 839377.

Email: info@foster-gmbh.de

Foster Refrigerator

Oldmedow Road

Kings Lynn

Norfolk

PE30 4JU

Tel: 01553 691122

Fax: 01553 691447

Website: www.fosterrefrigerator.co.uk

Email: sales@foster-uk.com

a Division of 'ITW (UK) Ltd'

FXT CAB/ SM 06/07